

PROTEKT® 600 STAND

SIT-TO-STAND PATIENT LIFT



Model: 34600



BEFORE USE:



Ensure the product has been assembled according to the instructions in this manual. All operators should read and understand the instructions for safe and proper operation of the patient lift.

Thank you for choosing Proactive!

To better serve you, please record the following information for future use:

Supplier Name: _____

Supplier Telephone: _____

Product Serial Number: _____

Date of Purchase: _____

INSPECT YOUR MERCHANDISE

Upon receipt of your patient lift, verify that all merchandise is complete and free from any shipping damage. Refuse delivery if the packaging appears to be badly damaged. If the merchandise is received damaged or is missing components, contact the shipping company immediately and file a claim.

For further assistance, contact your local dealer or Proactive Medical Products at the following:

Proactive Medical Products
270 Washington Street
Mount Vernon, NY 10553
Tel: 855-237-7622
www.proactivemedical.com

Product Description

The Protekt® 600 Stand 34600 allows the patient to be lifted and transferred safely with minimal physical effort provided by the operator. The 34600 uses an electric actuator to lift patients weighing up to 600lbs, from a sitting to a standing position from either a bed or a chair for transferring. The lift has a standing platform to be used while transferring patient from one surface to another, also included is a cushioned knee pad for additional comfort and support while patient is being transferred. The 34600 has a compact base for maneuvering easily while still providing a wide lifting range. The 34600 is compatible with the stand assist sling and sani-sling with the option to add the knee and buttocks support straps.



















Intended Use

The 34600 is intended for patients who are lacking leg strength in their lower extremities but are still able to bear weight. The 34600 is intended to assist with standing from a seated position while using the commode, changing clothes and/or to relieve pressure. The 34600 is intended to have one caregiver operate the lift to perform the transfer. Transfers are intended to be performed on a flat, dry surface and lifts are not to be used in high humidity environments for extended periods of time.

DEFINITIONS & SYMBOLS

In this manual the user refers to the patient or resident and may be used interchangeably at different times. Caregiver refers to the operator or person who is assisting with the transfer.

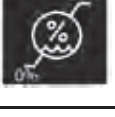
Symbols used in this manual and on the product and their meanings:

	Warning! Failure to heed this warning may result in damage to the product or serious injury to the operator and/or user.		Do Not Bleach. No bleach product may be used. The garment is not colorfast or structurally able to withstand any bleach.
	Important instructions follow. Read and understand the instructions in the manual before using the product.		Do Not Dryclean. Garment may not be commercially drycleaned.
	Type BF applied part. Refer to the part of the medical device which come into physical contact with the patient in order for the device to carry out its intended use.		Do Not Iron. Item may not be smoothed or finished with an iron.
	Class II symbol. To identify equipment is designed that a connection to electrical earth (ground) is not required.		Tumble Dry, Normal, Low Heat. A machine dryer may be regularly used at a maximum of Low Heat setting.
	Note! Important information concerning the product and/or its correct and proper usage follows.		Do Not Dry. A machine dryer may not be used.
	Advise the operator to consult the accompanying documents before use.		Machine Wash, Hot. Initial water temperature should not exceed 82°C or 180°F.
	Right side up		Do Not Wash
	Fragile, handle with care.		Keep dry
	Carton storage temperature limit of -25°C to 70°C.		Carton storage humidity limit of 0% to 90%.
	European Conformity mark, the product conforms to European Medical Directive 93/42/EEC and meets applicable health, safety and environmental requirements.		Handle with care



Safety Instructions

A Protekt® 600 Stand will provide years of service if it is properly maintained as any electric and/or mechanical equipment requires. Please pay careful attention to the following important information regarding the care, maintenance, and operation of the patient lift. Carefully read these instructions before assembling the lift, or attempting to lift a user with the device.

- Before attempting to lift any patient, please practice operating the lift and explain the lift procedures to the patient.
- Please provide special assistance under the caretakers' discretion. (i.e. patients who are comatose, spastic, agitated, or otherwise severely handicapped).
- The patient lift should be used solely for transferring a user/patient from one utility (beds, chairs, toilets, etc.) to another. The patient lift should not be used for transporting or moving any patient from one location to another location.
- During lifting or lowering, whenever possible, always keep the base of the lift in the widest position.
- The base of the lift should be closed before moving the lift.
- Do not roll casters over any object while the user/patient is in the sling.
- Do not lock casters during lifting.
- While being lifted in a sling, always keep the user/patient centered over the base and facing the caregiver operating the lifter.
- Never leave the user/patient unattended during lifting.



WARNING!

- **NO** modification of this equipment is allowed. It is unsafe to modify the equipment from its original state. This product is deemed safe to use with only the original parts as delivered. Unauthorized use of any modified equipment may result in serious injury or death.
- **DO NOT** replace any components of the lift without consulting with Proactive Medical Products, and must follow proper instruction from Proactive when replacing any components.
- **DO NOT** service any parts of the lift while in use with a patient.
- It is **NOT** safe to load the equipment more than the indicated maximum safe working load.
- **IF** any accessories with lower load capacity than the equipment itself is used, **DO NOT** load the equipment more than the lowest maximum safe working load.
- **REMOVE** the battery pack if the lift will not be used for some time, to prevent battery leakage. **PERIODICALLY** check the battery pack and the charger.
- This equipment **DOES NOT** consist of any materials or ingredients to which patients are exposed, that may cause bodily harm or injury.
- Prolonged exposure or physical contact with any part of the equipment **WILL NOT** cause skin irritation, allergic reaction, etc.
- Using accessories, detachable parts, or materials not described in the instruction manual **MAY RESULT IN SERIOUS INJURIES**.
- Keep the equipment away from children and pets when in use. **IT MAY CAUSE SERIOUS INJURY OR DEATH**.
- Keep the equipment away from any pests or pest infested area. Diseases transferred from pests to the equipment **MAY CAUSE SERIOUS ILLNESS** to patients upon contact.
- If the lift is exposed to the sun for long periods of time, be **CAUTIOUS** as the surface of the lift may be hot.
- There are no risk if the lift is exposed to reasonably foreseeable environmental conditions.
- **CAUTION!** The controller contains parts and assemblies that could be susceptible to **damage by electrostatic discharge (ESD)**. To reduce the likelihood of this, one should be grounded prior to using the controller.
- **DO NOT** use the lift on a inclined surface that is greater than 5°.
- **CAUTION!** The black plastic bolt caps can fall off the bolt and is a **choking hazard**. If the cap will not stay on the bolt, replace it immediately.

FEATURES & OVERVIEW

- i** • Prior to assembly, unpack and inspect all parts from the shipping carton. Contact your dealer immediately if any parts are damaged or missing.
- Easy tools are provided to assist with initial set up. To ensure maximum safety, product should not be put into use until all connections are tightened using standard tools.

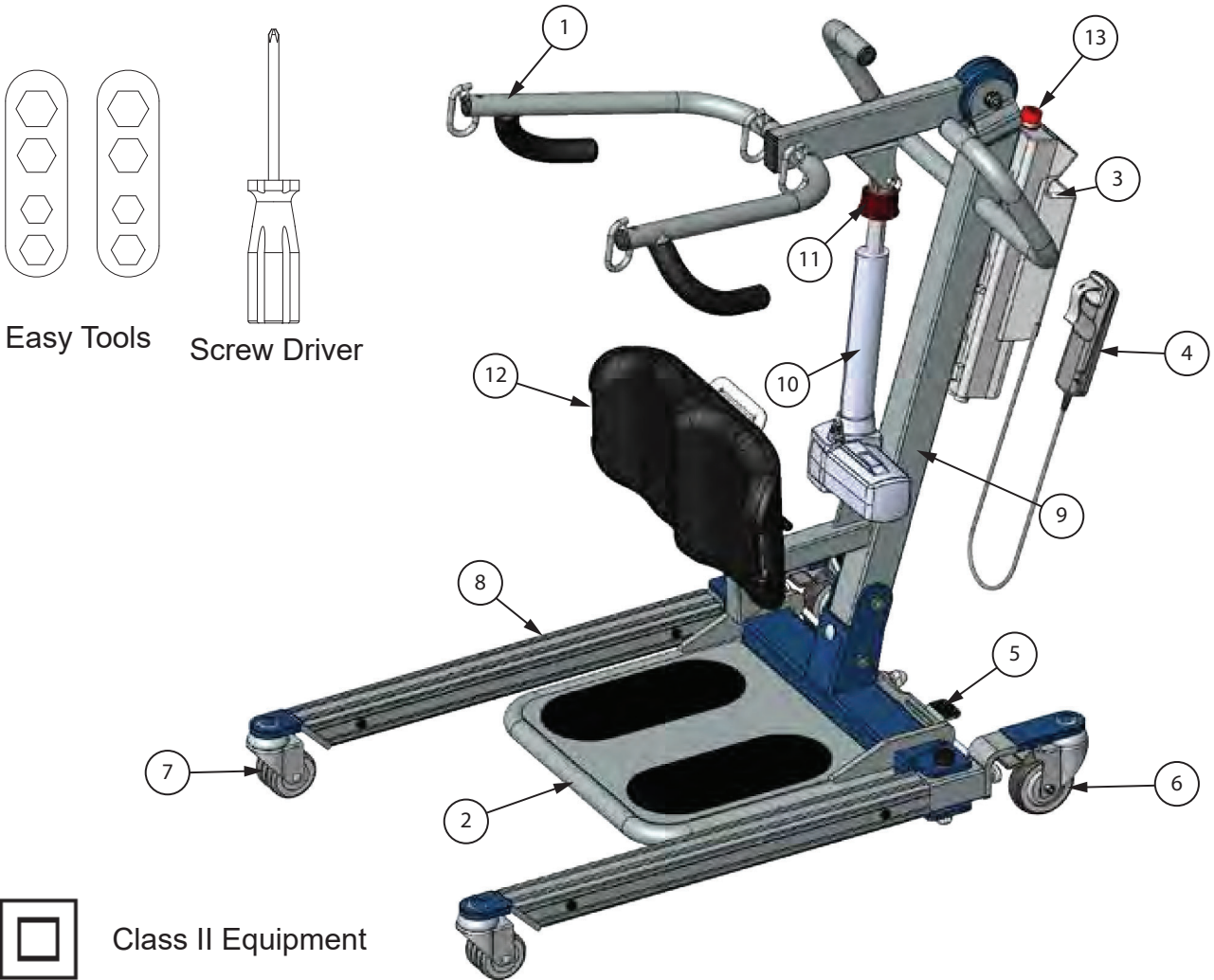

1	Boom	14.60 lb (6.6 kg)	6	Rear Caster	11	Emergency lowering
2	Footplate	15.00 lb (6.8 kg)	7	Front Caster	12	Knee Pad 11.60 lb (5.3 kg)
3	Control Unit	11.00 lb (5.0 kg)	8	**Base	13	Emergency Stop Button
4	Hand Control	0.70 lb (0.3 kg)	9	Mast		Charger 0.6 (0.3 kg)
5	Leg Opening Pedal		10	Actuator		

** Heaviest detachable part

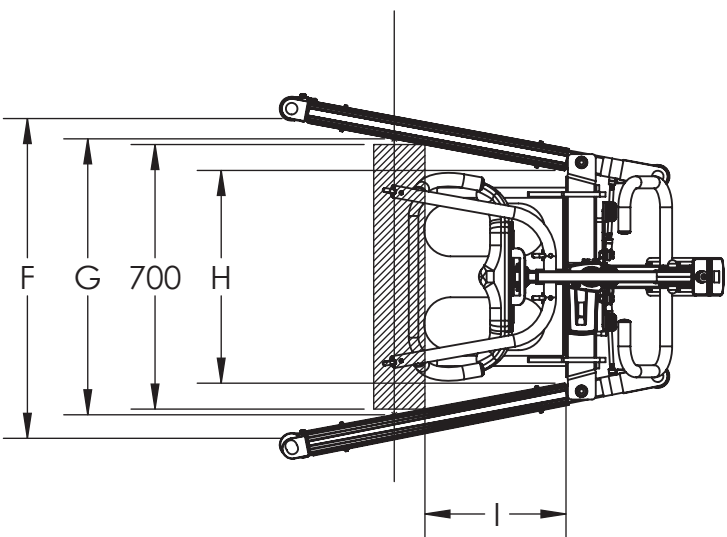
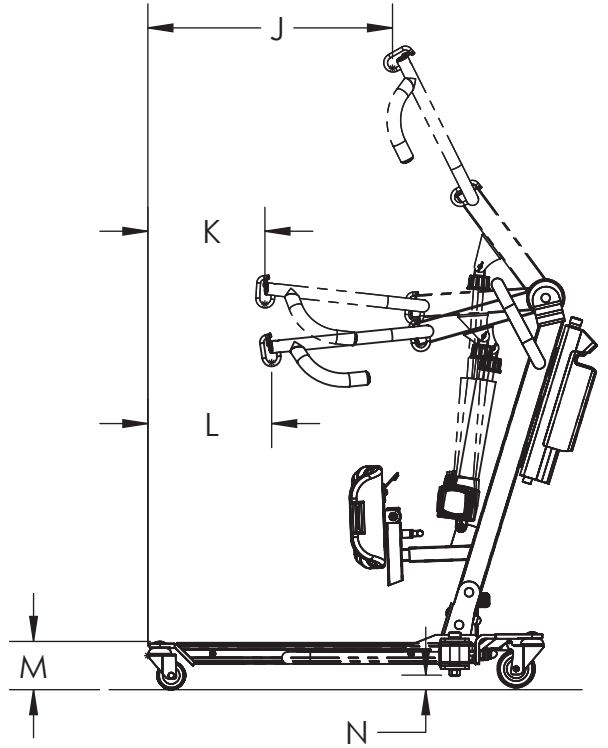
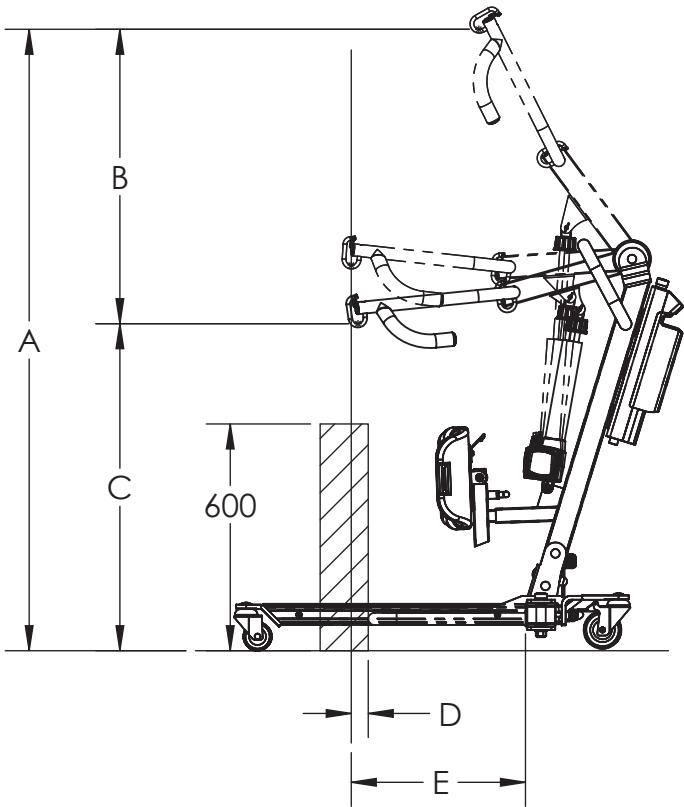

34600	
mm (in)	
A	1644.3 (64.7)
B	779.0 (30.7)
C	865.3 (34.1)
D	44.9 (1.8)
E	460.9 (18.1)
F	840.7 (33.1)
G	788.4 (31.0)
H	567.8 (22.4)
I	277.9 (10.9)
J	647.3 (25.5)
K	309.7 (12.2)
L	327.5 (12.9)
M	119.4 (4.7)
N	36.0 (1.4)

SPECIFICATIONS & OPTIONS

Specifications of Control Unit	
Input Voltage	220-240 AC 50/60 Hz 110-120 AC 60 Hz
Output Voltage	24 DC
Battery Pack	24 DC 5AH
Control	Handset and Panel
Protection Class	IP54 Protection against dust and splash of water
Sound Level Under Full Load	16db
Sound Level Under No Load	11db
Cycles Per Charge	25 full cycles under full load
Over-Duty Warning	by CD
Battery Status	by CD
Duty Cycle	1 Duty cycle Max 2 minute ON 1 minute OFF

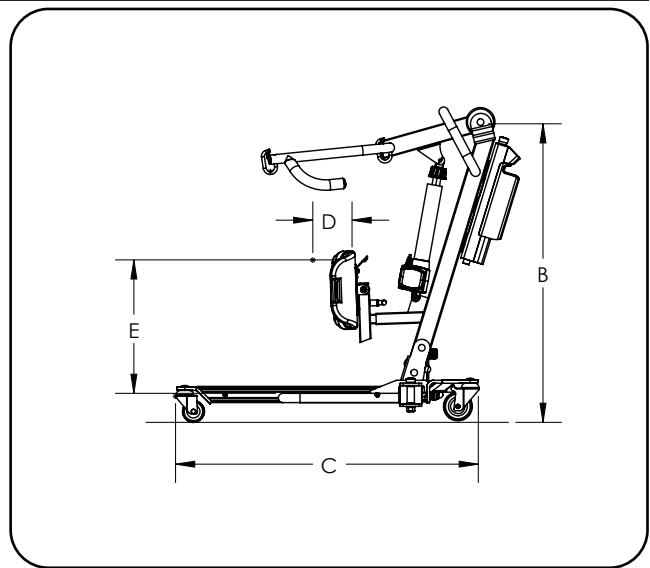
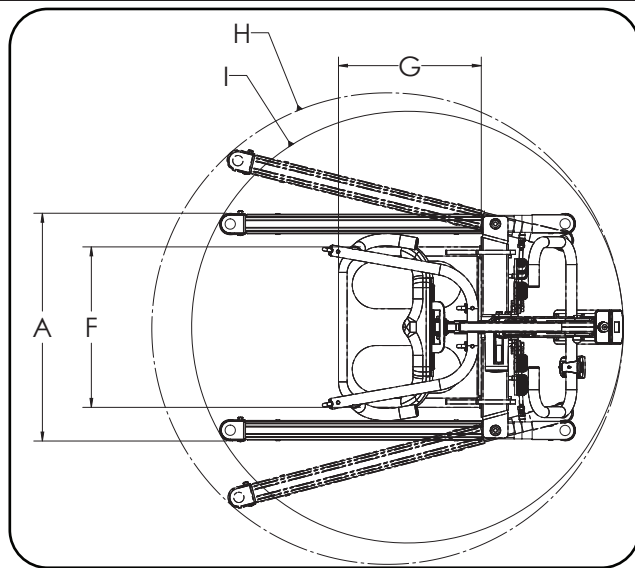

Dimensions & Specifications		
Model		34600
Safe Working Load		600 lb
Unloaded Lift Weight		132 lb
A	Base Ext. Width - Closed	26.4"
B	Mast Height	41.7"
C	Base Length	41.3"
D	Knee Pad Depth Range	2.8"
E	Knee Pad Height Range	20.2" - 23.7"
F	Footplate Width	18.5"
G	Footplate Length	16.6"
H	Base Opened Turning Diameter	54.2"
I	Base Closed Turning Diameter	50.0"

Standard Features	
1	4-Points Boom
2	4" Rear Caster with Brake
3	3" Dual Front Caster
4	Power Control Unit
5	Single Piece Molded Kneepad With Handlebar
6	Height & Depth Adjustable Kneepad Position
Optional Features	
2	Charging Cradle
4	Second Battery pack

*Proactive is committed to continuous improvements of our products therefore the specification, dimensions, and features listed above are for guidance only and are subject to change without prior notice.

Installation

Step 1: Remove the base from box.

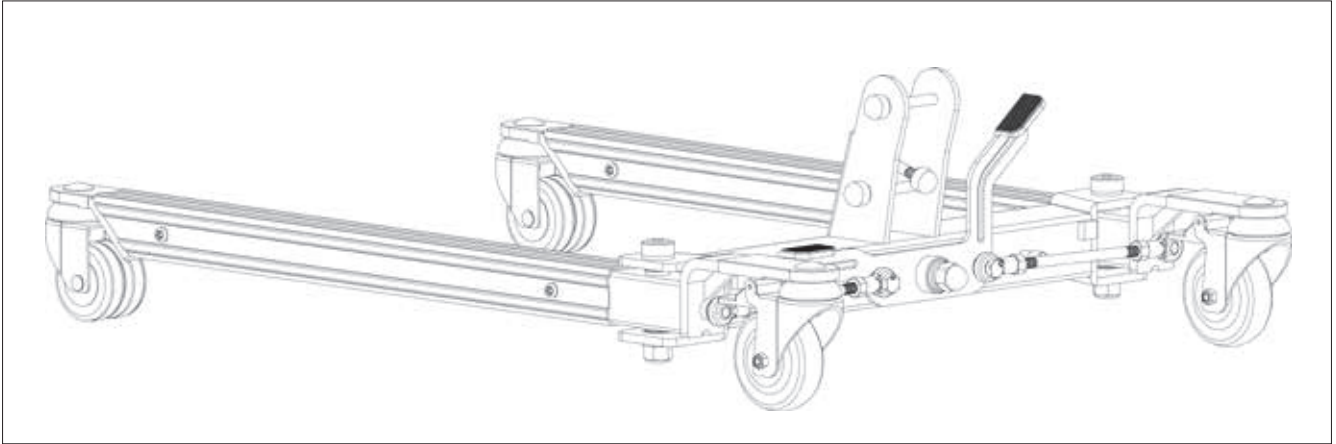

Step 2: Remove all the plastic caps, then all the bolts, nuts and washers on the base bracket.

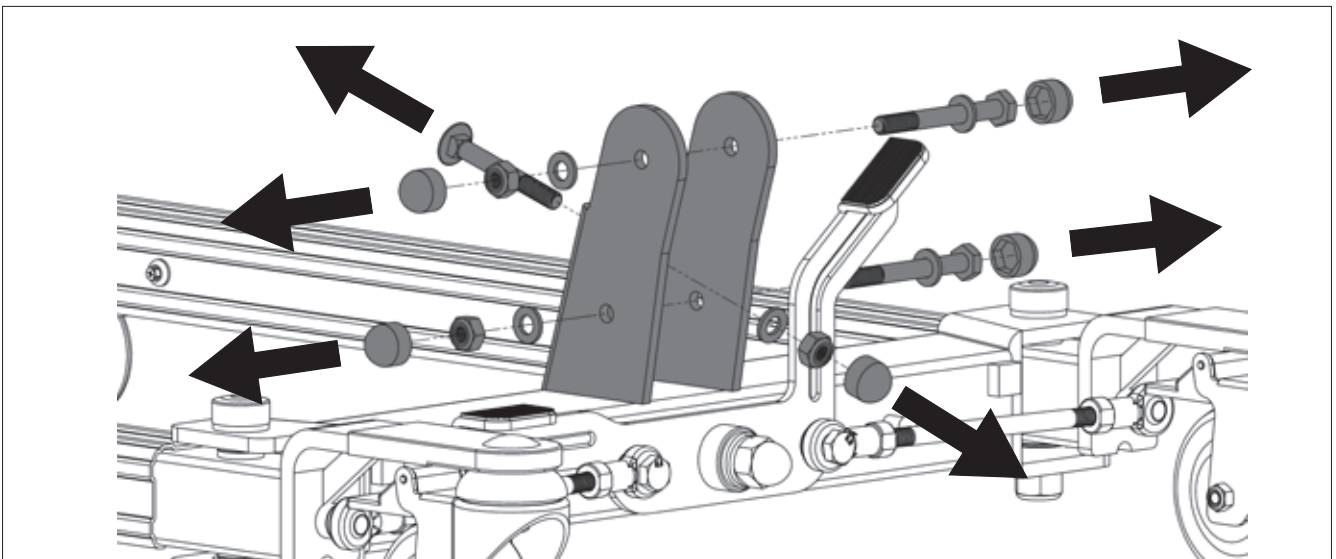

Step 3: Insert the mast and align the upper hole on the mast with the upper hole on the bracket. Secure the mast to the bracket using the side bolt and nuts as follows, reinsert the plastic cap after the screw is tightened using the EZ Tools.

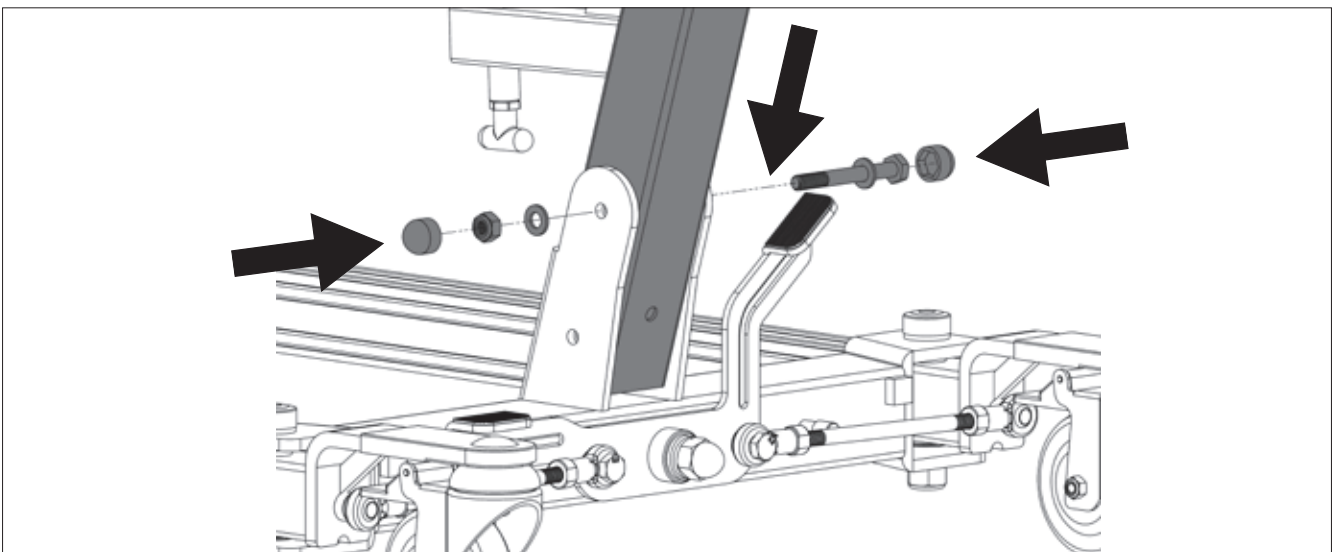

Step 4: Other two holes should be aligned, align the holes if needed. Reinsert and tighten the bolts using the EZ Tools as follows.

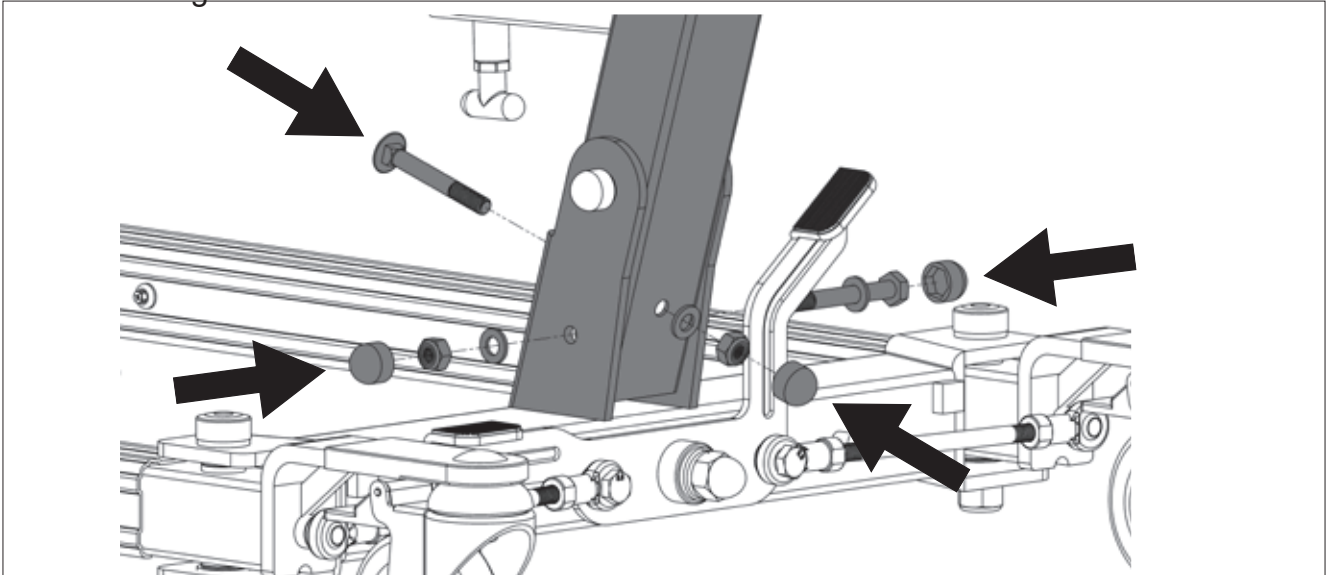

Step 5: Remove the plastic caps, then all the bolt, nut and washers on the boom. Tighten the bolt and nut using the EZ Tools as follows.

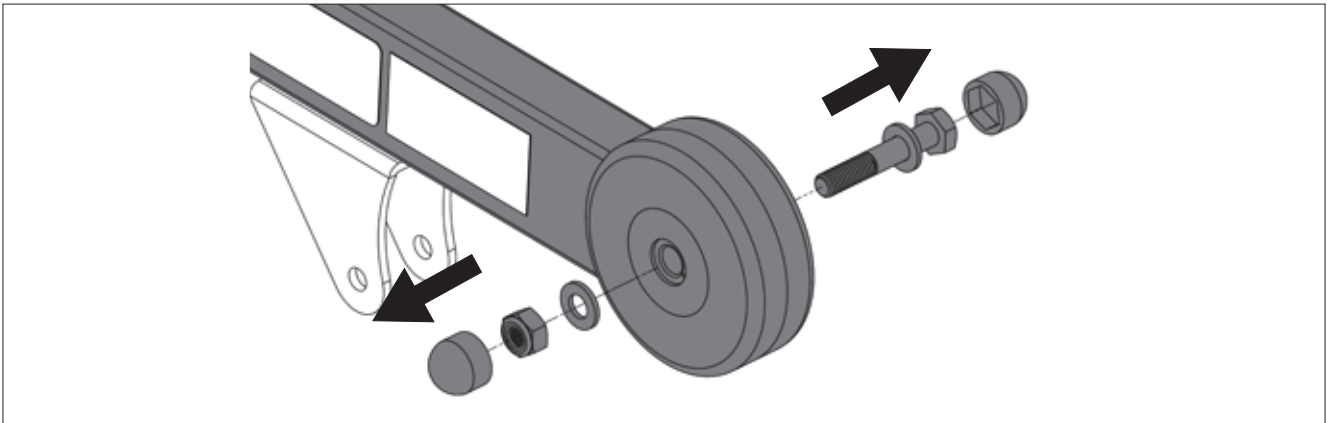

Step 6: Secure the boom to the mast using the bolt, nut and washer. Reinsert the plastic caps after screw is tightened using EZ Tools.

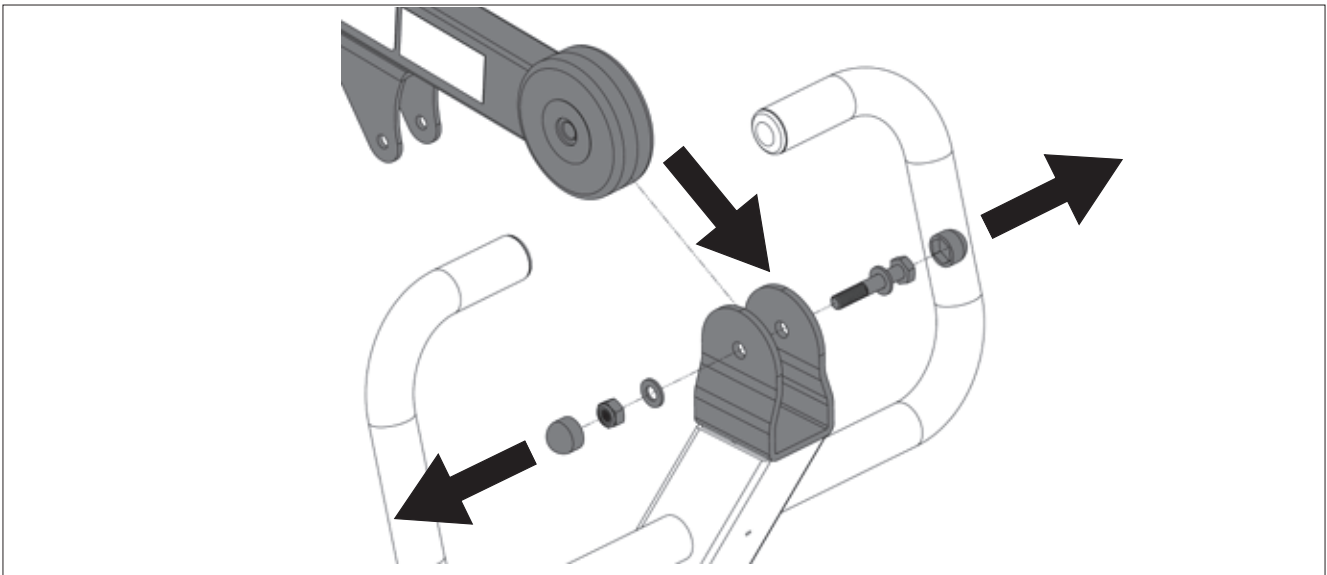

Step 7: Secure the lower end of the actuator to the mast bracket using a pin and retaining ring as shown.

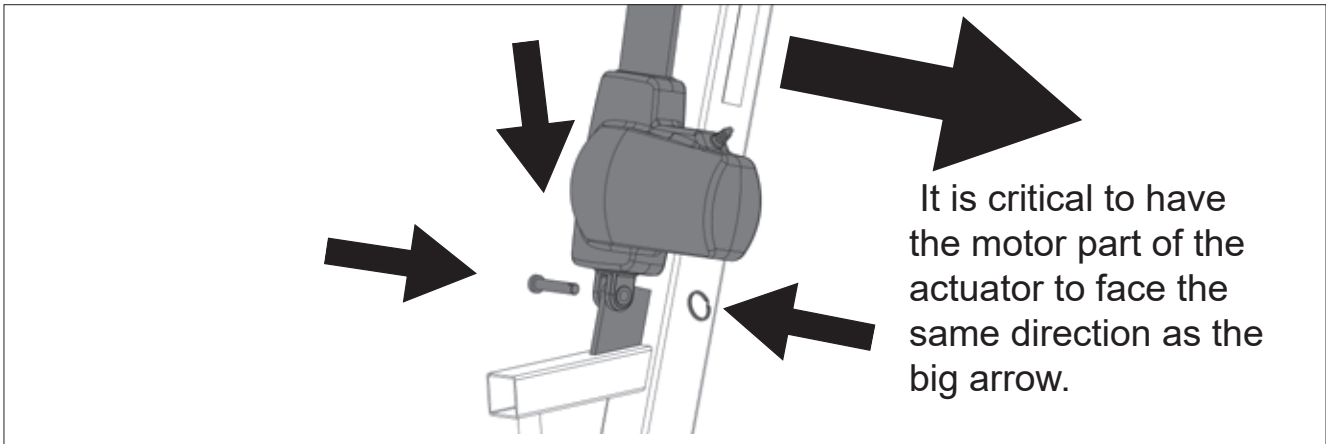

Step 8: Secure the upper end of the actuator to the boom bracket using a pin and retaining ring as shown.

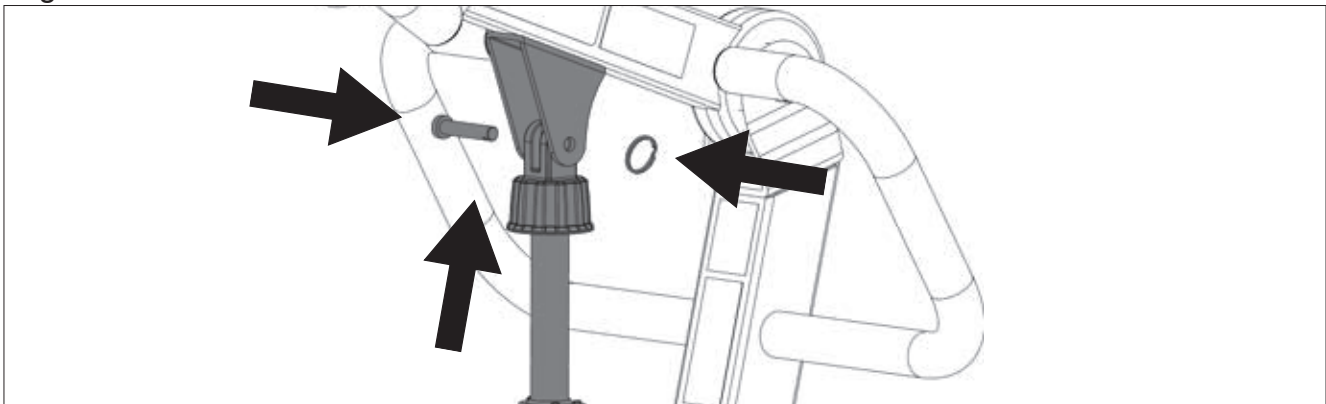

Step 9: Attach the footplate to the base using the two hooks by lowering it onto the top surface of the base. Make sure the hooks are sitting next to the small block protruding at the back of the base as follows.

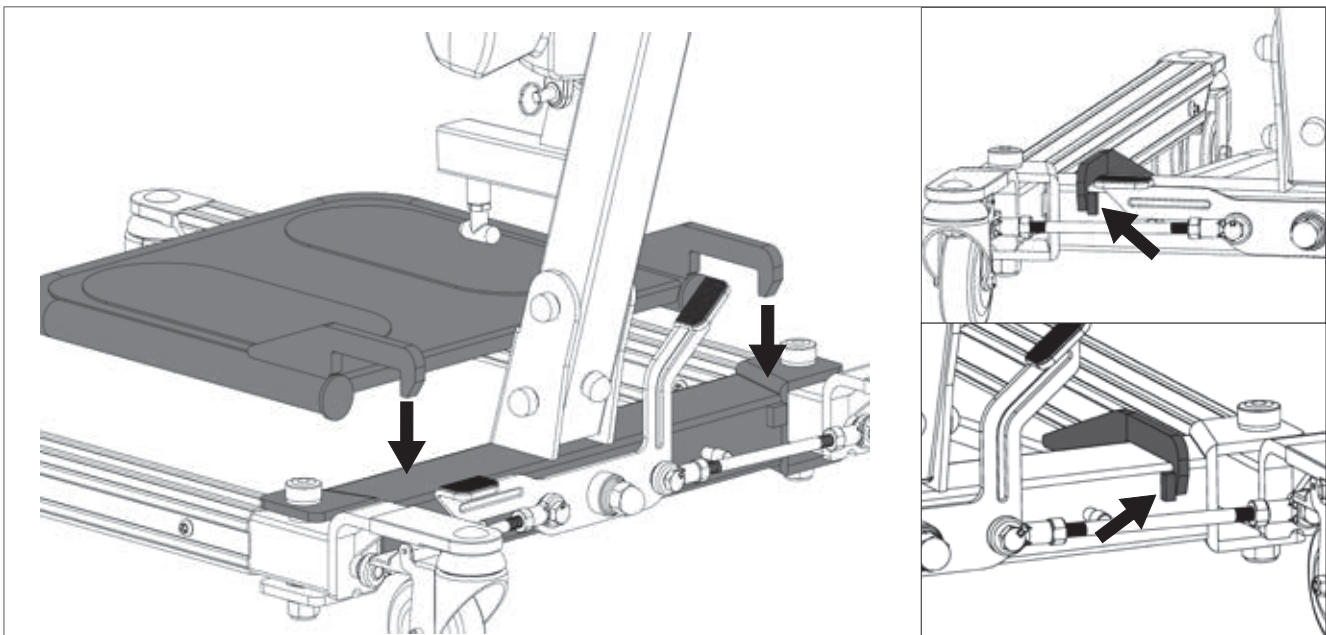

Step 10: Attach the included plastic washer to the kneepad frame as shown in the picture below, and place them in between the kneepad bracket. Secure the parts with the bolt, nut and washers using EZ Tools.

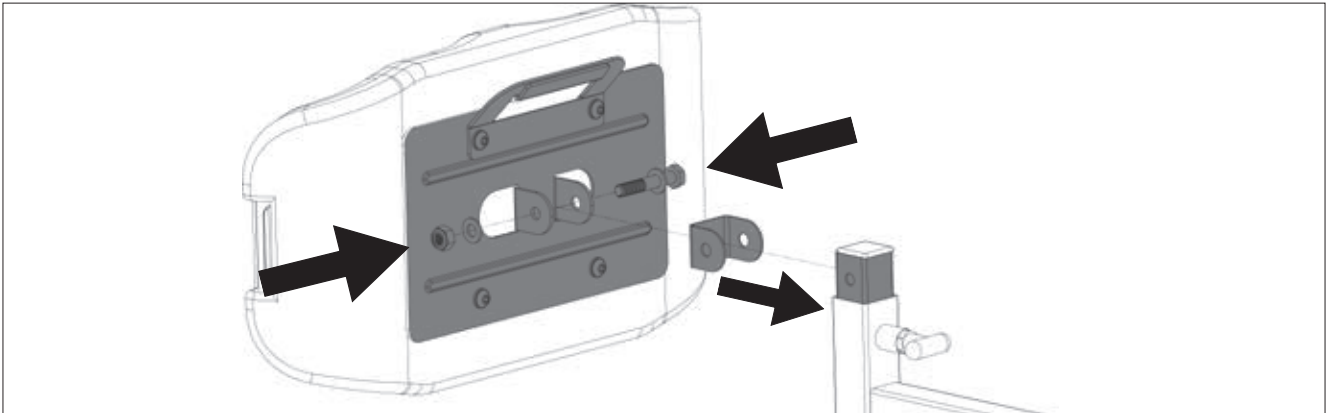

Step 11: Insert the kneepad frame into the tube located on the mast. Pull the handle below the tube to fully insert the frame, and release the handle to secure the frame in place.

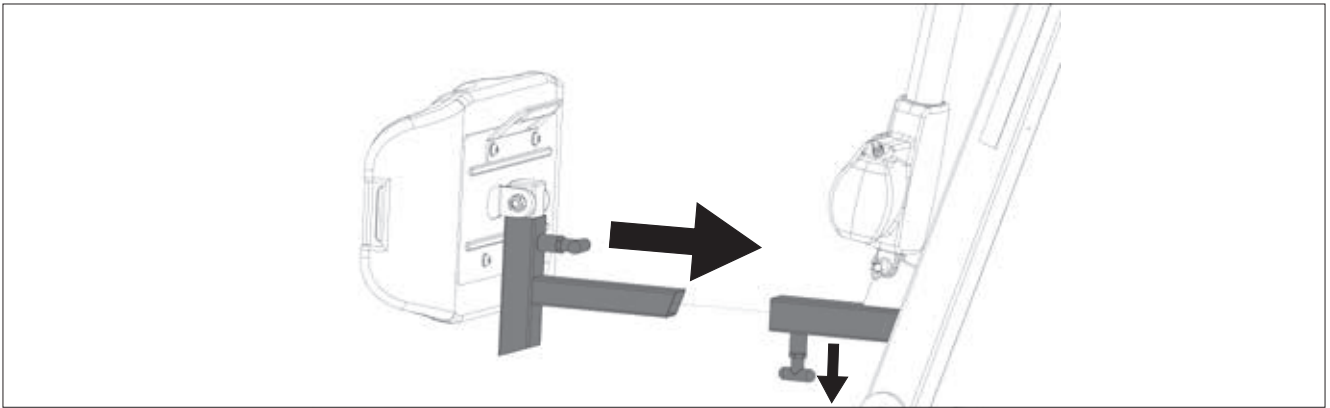

Step 12: Use the two handles to adjust the position of the kneepad by sliding it in and out of the tube.

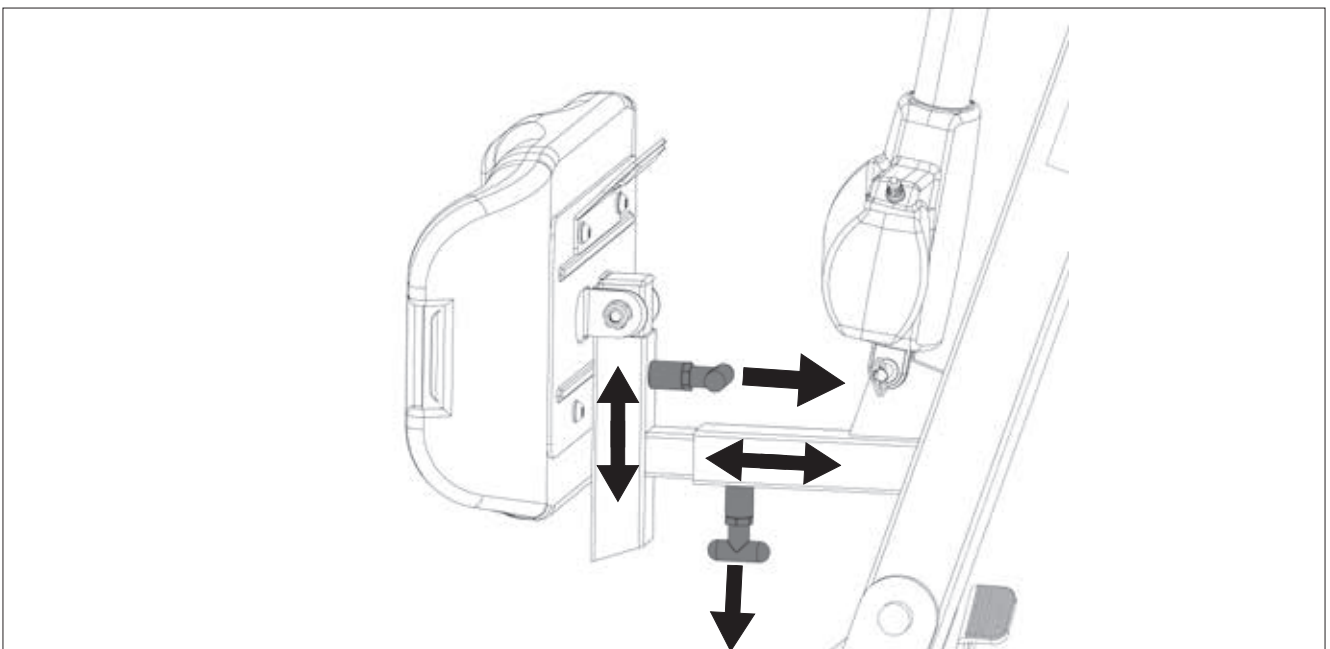

Power Control Unit

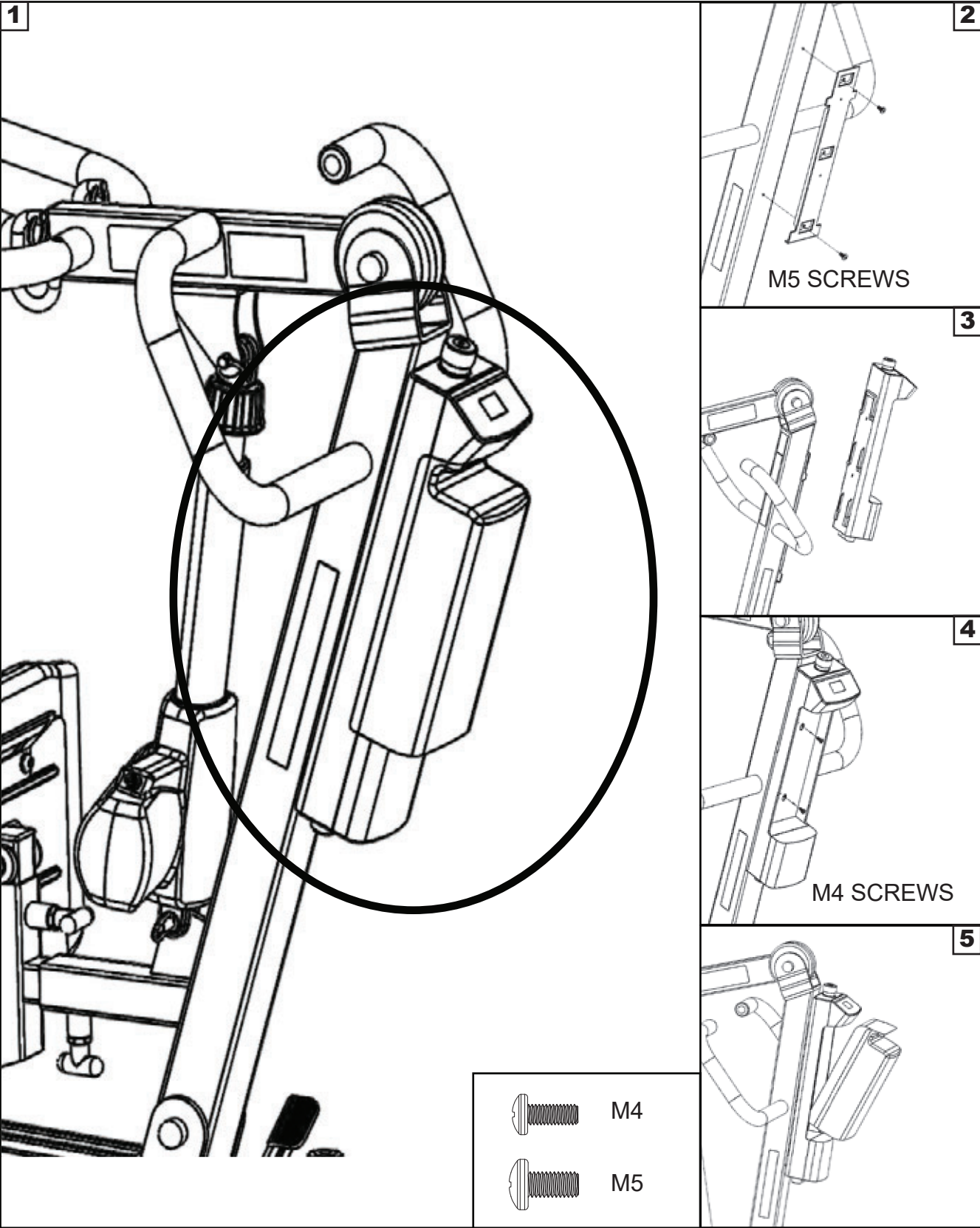

Operating Instructions

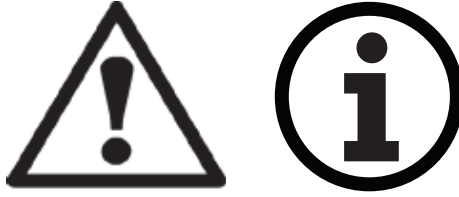

Double check all assemblies for tightness and read operating instructions carefully prior to use.

For optimum performance, the lift should be transported and stored in following condition range:

- -25°C to +5°C (-13°F to 41°F), and
- +5°C to +35°C (41°F to 95°F) at a non-condensing relative humidity 0% to 90%
- +35°C to +70°C at a water vapor pressure up to 5 kPa

For optimum performance, the lift should be operated in following condition range:

- at a temperature range of +5°C to +40°C (+41°F to +104°F)
- at a non-condensing relative humidity range of 15 % to 90 %, but not requiring a water vapor partial pressure greater than 5 kPa
- 70 kPa to 106 kPa atmospheric pressure

The lift will not have any potential electromagnetic or other interference with other devices.



PREPARATION BEFORE LIFTING

- Twist the RED EMERGENCY STOP BUTTON clockwise.
- Verify the Lifting and Lowering Functions by pressing either the UP or DOWN button on the hand control once.
- Position the base of the lift around or under the object.
- Widen the base and disengage the caster brakes.



Do not attempt to transfer a patient without prior approval of the person's nurse. Also, do not transfer without having studied the instructions and performed several practices in operating the product. Together (with the patient's doctor, nurse, or medical attendant) select a sling that is both practical and comfortable. The sling selected should be one that serves the needs of the patient, while providing the patient with optimal safety. Never interfere with the lift, unless instructed by the attendant. Have a doctor, nurse, or medical attendant (experienced in the use of the Protekt® 600 Stand) present during the first few times the lift is used to transfer a new user.

Power Control Unit Overview

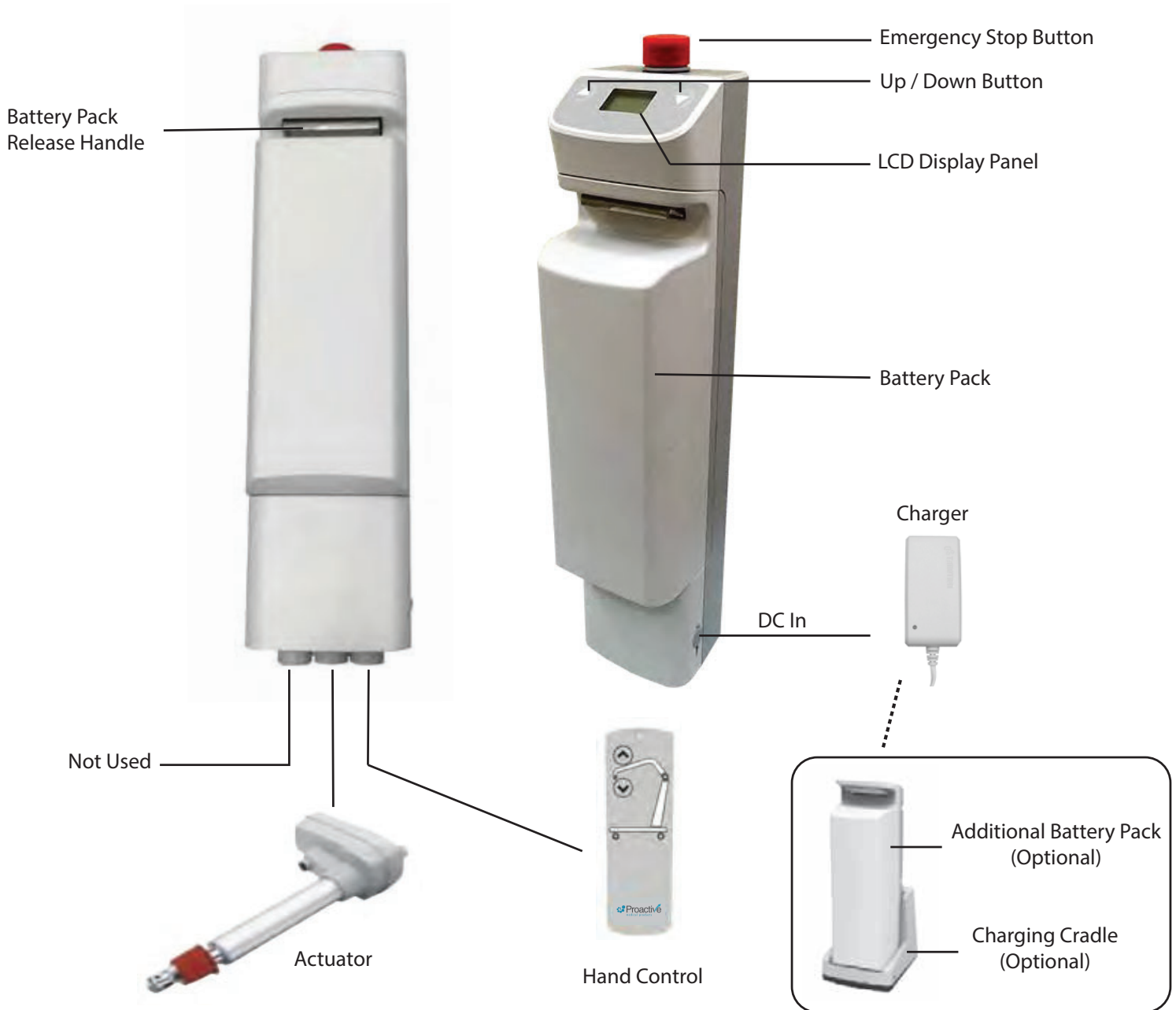

1. Connect Actuator as shown above.
2. Connect Hand Control as shown above.
3. The battery should be charged daily to prolong the battery life.

WARNING!

Contains a long charger cord that may cause strangulation if used improperly!
Keep long charger cord out of walk area where it poses a tripping hazard

Handle the charger port on the controller facing away from the wall for easy disconnection

When removing the battery, need to secure the battery with both hands as it can cause injury if dropped

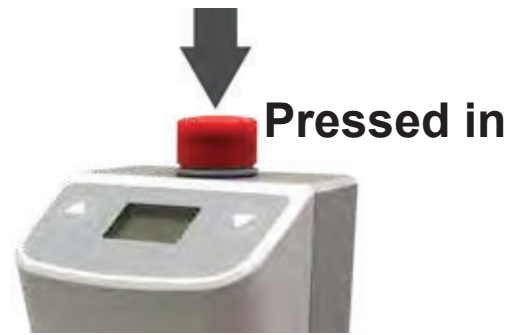

LCD Display Panel Signs

When the emergency stop button is released, the LCD Display Panel will show one of the four signs below.

- The sign will display for 5 seconds.
- Then the lift will go into standby mode and the sign disappears.
- The lift is ready for use.



Charging: DC Charger or Charging Cradle

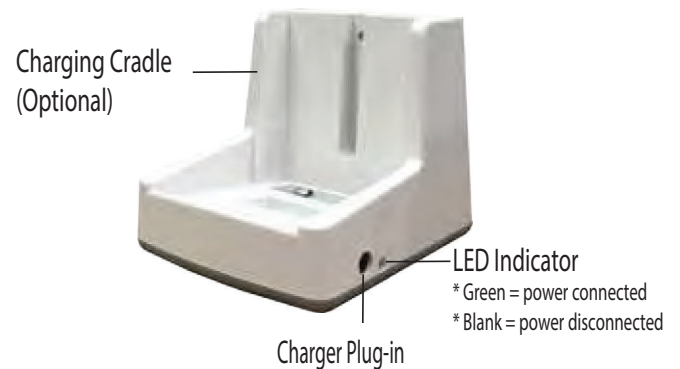
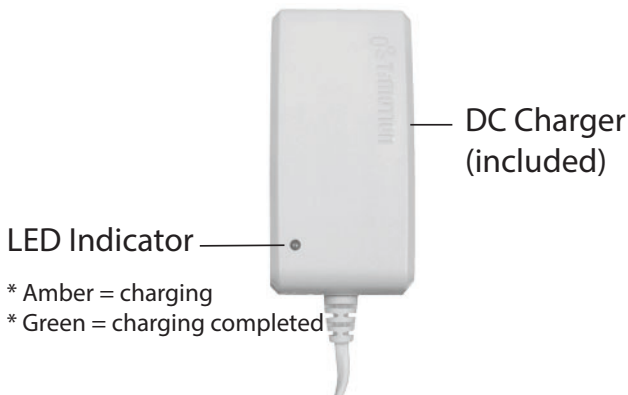

LCD Display Panel Signs - Charging

During charging, the LCD Display Panel will show one of the four signs below.

- The DC Charger must be connected.
- The emergency stop button must be released.
- The battery will not be charged if the emergency button is pressed in.



Operation Unit Control

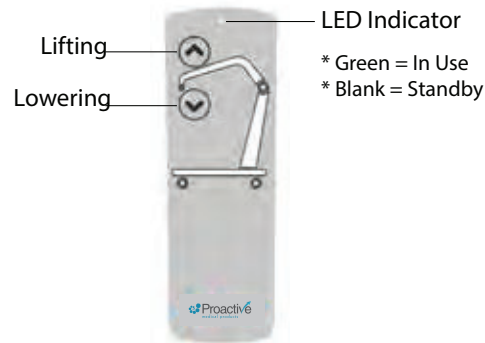

Button	Press Button	Release Button

Operation Unit Control Panel



Button	Press Button	Release Button

Warning! - Battery Low and Charging is Needed

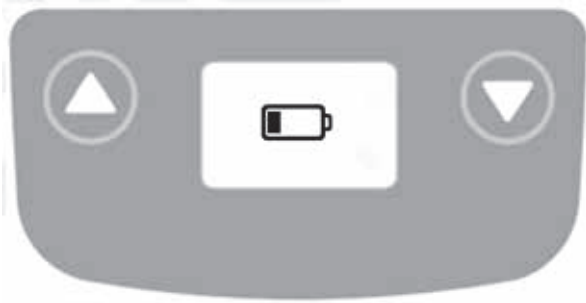

If the battery needs to be charged, the LCD Display Panel will show a blinking low battery sign shown on the left either when the emergency stop button is released or when a button on the LCD Display Panel is pressed.

- Lift is still functioning.
- Buzzer will beep every 2 seconds.
- Battery needs to be charged immediately after use.

Warning! - Overloaded



During lifting if the lift is overloaded, the LCD Display Panel will show the sign on the left and lifting will be deactivated immediately.

- The buzzer will beep 3 times.
- Lowering the lift by pressing the DOWN button is still allowed.
- The emergency stop button must be pressed in and then release the button before further lifting.

Warning! - Charge Battery Immediately



If the battery is critically low, the LCD Display Panel will show the sign on the left either when the emergency stop button is released or when a button on the LCD Display Panel is pressed.

- Lift operation is deactivated.
- Battery needs to be charged immediately before further use.

Available slings compatible with Patient Lift

Sit-to Stand Sling	
30129	Sit to Stand Solid Patient Stand-Assist Sling - Medium
30130	Sit to Stand Solid Patient Stand-Assist Sling - Large
30131	Sit to Stand Solid Patient Stand-Assist Sling - X Large
30139	Sit to Stand Solid Patient Stand-Assist Sling - XX Large
Padded Sit To Stand Sling	
30661	Deluxe Sit-to-Stand Sling, Padded, Small
30662	Deluxe Sit-to-Stand Sling, Padded, Medium
30663	Deluxe Sit-to-Stand Sling, Padded, Large
30664	Deluxe Sit-to-Stand Sling, Padded, X-Large
Transfer Sling	
30134	Sit to Stand Transfer Patient Sling - Large
30136	Sit to Stand Transfer Patient Sling - X Large
Buttocks Support Strap	
30669SA	Sit to Stand Buttocks Support Strap, Standard
30669B	Sit to Stand Buttocks Support Strap, Bariatric
Knee Strap Brace	
31230	Sit to Stand Knee Strap Brace
Toileting/Sani-Sling	
30331	Toileting/Sani-Sling, Padded, Small
30332	Toileting/Sani-Sling, Padded, Medium
30333	Toileting/Sani-Sling, Padded, Large
30334	Toileting/Sani-Sling, Padded, X Large



Use only with Patient Lift. Do not use on patient in combination with other slings.



Do not use on patient with weight over 300 lbs.



Use only on patient lying flat.

FITTING STAND ASSIST SLING

Attach the shoulder straps to the hooks.

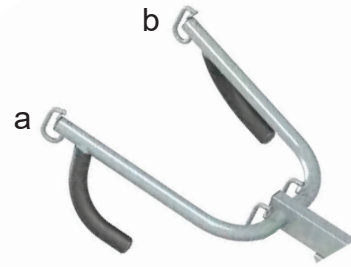
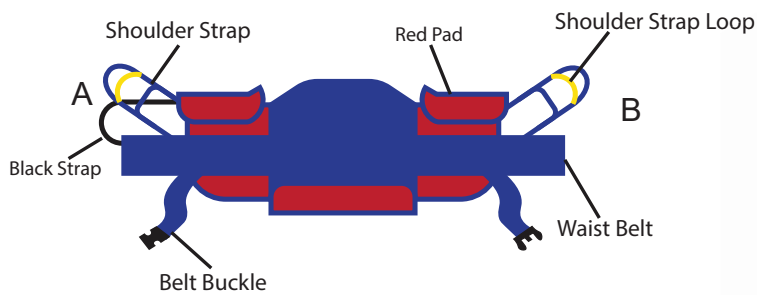

Sling Loop Options

SAFETY LOOP

CENTER LOOP

SHORT LOOP

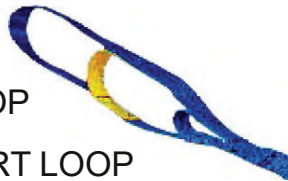

SAFETY LOOP - DO NOT USE FOR LIFTING

**safety loop is used with the center loop or short loop.

CENTER LOOP - reclined position

SHORT LOOP - upright position

1. Place sling behind seated patient with the 2 red pads under the arms.
2. Cross the adjustable chest belt over and fasten it securely using the buckle (adjust for comfort).
3. Cross the short black strap over and pull the left loop strap through the black strap.
4. Hook the two loop straps to the hooks ("A" to "a" and "B" to "b") on the lift boom using the same hook and loop sequence on each side.
5. The black strap should loop around both shoulder straps and will be straight across in front of patient to stabilize the sling during lifting.
6. Have patient grasp the arms of the boom and tilt head back slightly.
7. Make sure the patients feet are firmly on the platform and knees are touching the kneepads with kneecaps just above the padding.
8. Use the lift to complete the lift and pivot transfer.



BEFORE LIFTING THE PATIENT, PULL ON EACH SLING LOOPS TO ENSURE THE LOOP IS HOOKED ONTO THE SPREADER BAR PROPERLY

FITTING STAND ASSIST BUTTOCK STRAP

DIAGRAM 1

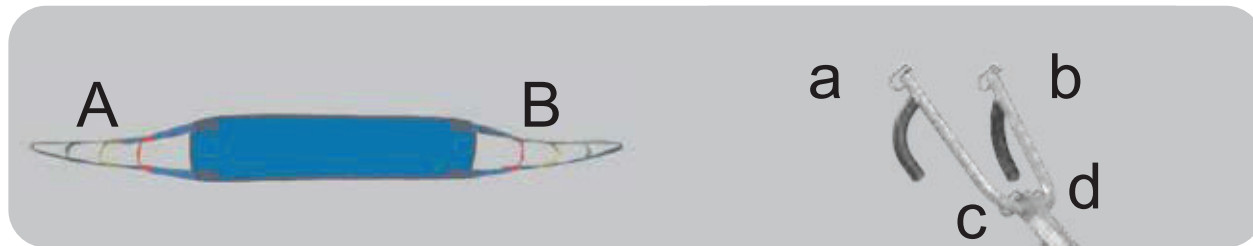

1. Check sling weight capacity for the patient being lifted. Do not exceed maximum safe working load.
2. Review the following procedures, and “FITTING STAND ASSIST SLING” procedures from previous page carefully prior to attempting lift.
3. Fit the Stand Assist sling onto the patient following “FITTING STAND ASSIST SLING” instructions.
4. Lift the patient up halfway using just the Stand Assist sling.
5. Attach the sling strap “A” to the hook “c” on the boom of the Stand Assist lift as in Diagram 1. Bringing the other side around the back of the patient’s buttocks (to fit like a park swing) and attach to hook “d”.
6. Position sling so it gives the greatest support to middle and lower part of the patient, and patient can lean on the sling for support while being lifted.

 The Buttock strap **MUST** be used with the Stand Assist sling. These slings are designed to compliment one another in providing the greatest comfort and security for the patient being transferred.

FITTING KNEE BELT

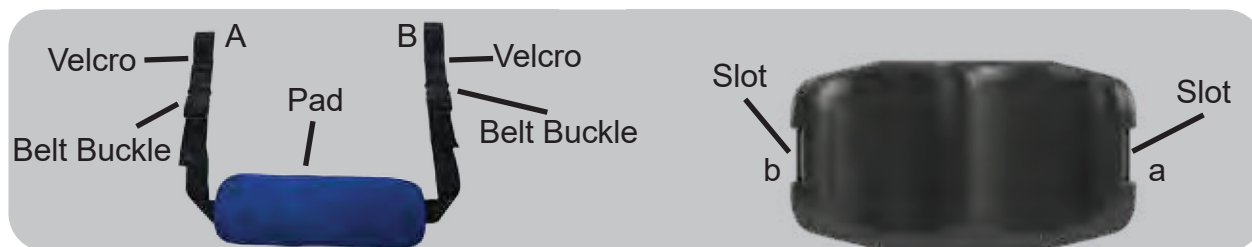

1. Pull open to Velcro.
2. Slide the Velcro through the slot. (“A” to “a” and “B” to “b”)
3. Wrap the Velcro around the slot and press the Velcro together.
4. Check to make sure the belt is strapped to the kneepad.
5. Repeat for the other side.
6. Make sure the pad is facing the back of your lower legs.
7. Adjust the strap on the belt buckles to fasten the knee belt and for comfort.

LIFT AND TRANSFER FROM BED

1. Fit sling as described in “Fitting Stand Assist Sling”.
2. Push lift towards patient. Open the base of the lift.
3. Position patient’s feet on the footplate and knees against the knee pad.
4. Attach the sling straps to the hooks.
5. Have the patient’s hands holding the handles. For patients who cannot hold the handles, have them hold their arms around the chest.
6. Press the “UP” button on the hand control.
7. Before the patient’s body has lifted from the bed, stop and make sure the sling is secured and patient’s knees are against the knee pad.
8. The patient should be comfortable with the pressure under the arms. If not, adjust the sling and try another loop option to release pressure.
9. Press the “UP” button until the patient’s body has completely left the bed.
10. Transfer to another object can be done without the patient in a fully standing position.
11. Close the base, and pull the lift away from the bed.
12. Lower the patient to the object intended.
13. To lift patient in a standing position, continue to lift until the patient’s knees are locked in a standing position.
14. At the standing position, patient’s knees may move away from the knee pad.
15. Close the base, and pull the lift away from bed.
16. Lower the patient to the object intended.
17. Reverse the above procedures when lowering the patient to the object intended.

LIFTING HINTS

- Prior to beginning a lift, have the patient lean slightly back and look at a 45 degree angle to the ceiling; this helps position the sling; and is recommended only at the start of lifting.
- Try the sling straps in various color positions to establish best fit.
- Always ensure the same color straps on each side are attached to lift.
- Should patients have a larger girth in mid section or back side area try the optional buttock strap to help with initial lift leverage.
- Remember this lift is designed for pivot transfers and it is not necessary to lift to full upright position; as long as the patients body clears the bed or the chair and vice versa, you can move the lift and place patient in new position.

LIFT AND TRANSFER FROM COMMUNE

TOILETING SLING

The Toileting Sling is be used to lift up a patient in a sitting position; it is not meant for the patient to be standing! The Toileting Sling supports the client under the thighs and across the mid-back area.

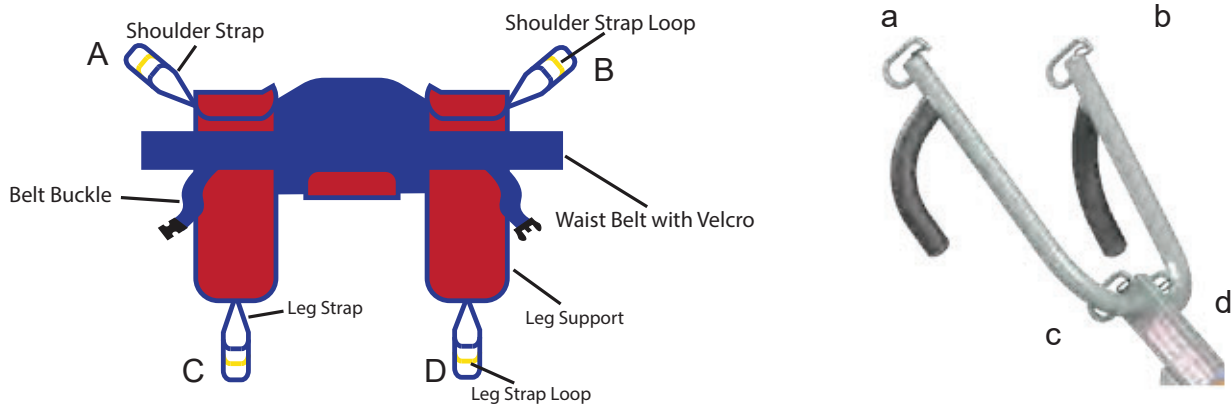

The Toileting Sling is not suitable for patients who have involuntary movements or patients with limited postural control.

Fitting the Toileting Sling

1. Slide the sling down patient's back to lumbar position.
2. Draw shoulder straps under the arms and around the chest into the front.
3. Draw Velcro waist belt around waist and press together to fasten.
4. **Secure the belt using the belt buckle (adjust for comfort).**
5. Draw each leg support under the thigh.
6. Crisscross leg straps by feeding one of the leg straps through the other strap.
7. Attach shoulder straps loop to the hooks in upper ends of the boom. ("A" to "a" and "B" to "b")
8. Attach the proper leg strap loop to the hooks in the lower end of the boom. ("C" to "c" and "D" to "d")

Maintenance & Inspection



- The Protekt® 600 Stand requires a minimum of service to keep it in proper working order and to assure safe operation. It is important that certain basic checks be performed periodically by the operator of the lift or by a qualified bio-med or maintenance staff.
- The manufacturer recommends that the following components and operating points be scheduled for periodic inspection at intervals not greater than 6 months (≤ 6). The manufacturer also recommends visual inspection prior to use for the additional points below (V). The periodic inspection interval and the visual inspection points are listed below.
- Note – Proactive assumes that the assembly instructions were performed properly and by a qualified individual. Proactive also assumes that the operator of the lift has been properly trained, reviewed all the training material and knows how to operate the lift.
- With proper use and care, the expected lifetime of the lift is 10 years or 20,000 cycles.
- The expected lifetime of the electrical components are 3 years.
- Contact Proactive for any recycling information.

	upon use	≤ 6 months
Check connections between boom and spreader bar for proper connection with pin key ring (for Patient Lifts)		
Check connection between boom and mast for improper connection looseness or wear		
Check spreader bar hook bolts for looseness or damage (for Patient Lifts)		
Key rings are present on spreader bar hooks (on patient lifts) and on boom hooks (on stand assist lifts)		
Check mast for bending or deflection		
Check all nuts and bolts for looseness		
Check all casters and axle bolts for tightness		
Check all casters for rotation and locking/unlocking (rear only)		
Apply multi-purpose grease to bearings if needed		
Check all weld joints for rust and cracks		
Confirm control box is securely affixed to the mast and battery pack is secured in control box		
Confirm a tuator is secured between the boom and the mast with the pins and key rings		
Confirm manual emergency lowering mechanism on a tuator operates properly		
Confirm red button on control box shuts off all power when pressed		
Confirm all cables at the bottom of the control box are properly connected		
Inspect the body of the sling and all loops or connectors that could attach to the spreader bar for signs of wear damage or fraying		
Inspect Clean	As needed	As needed

Cleaning and Disinfecting

Cleaning of the lift

- Use pH-neutral detergents only.
- Remove the battery from the controller.
- Clean lift surfaces, control box and hand control with a damp cloth using pH-neutral detergent.
- Remove debris and hair from the casters and make sure the casters can spin and swivel freely.



- Solvents or strong liquids or abrasive cleaning products will damage the surfaces of the lift.

Cleaning of the sling

- Check with sling label for washing condition.
- As for minor cleaning between patient uses, we recommend wipes with water-soluble soap or isopropyl alcohol.
- For slings with rigid supports, remove the plastic inserts before washing. (Look for an opening near the plastic inserts for removal).
- Machine wash warm or cold.
- Do not wash with other colors.
- Air dry or very low dryer heat.



- DO NOT USE BLEACH.
- DO NOT clean or wash disposable slings.
- REPLACE a sling when it show signs of deterioration.

Deterioration of sling

- Contact Proactive for “Guideline for Identifying Deteriorated Slings” if needed.

Disinfecting of the lift and sling

- Inspect slings prior to each use for contamination from previous use.
- Use isopropyl alcohol for any disinfection purpose.



- Wash a reusable sling for serious contamination.
- Replace a disposable sling for any contamination.
- Reusing a contaminated sling can cause serious bacterial infection.

Troubleshooting Guide

The following list of encountered problems and solutions will assist you in determining what may be causing your patient lift not to function as designed. If you have a problem occurring which is not listed below please contact your dealer or technical support for help. Do not attempt to repair or replace components or parts on your lift as this may void your warranty or cause further problems that may result in patient injury. Stop using your lift immediately if it is not functioning correctly or any warning beeps are heard.

I need to re-charge my batteries often or they fail to hold a charge when I charge them

- Replace the batteries or battery pack as they are at the end of their life cycle.
- Batteries should be changed every 18-24 months depending on usage.

The actuator will either go up or down but not both

- Replace your hand control as it is at the end of its life cycle.
- Your control box may be malfunctioning.

There is a grinding sound inside the actuator when lifting

- Replace your actuator as the internal gears are stripped.

The actuator stops and starts while lifting or lowering

- Replace the batteries or battery pack as they are at the end of their life cycle.

My lift will not operate even though it shows the batteries are charged

- Unplug the AC power cord from the control box as the lift will not work when the control box/charger is connected to AC Power.
- Check to make sure the hand control is properly inserted all the way into the control box port.
- Check to make sure the actuator plug is properly connected and inserted all the way into the control box.
- Your hand control needs to be replaced as it is at the end of its life cycle.

If there is a problem you could not solve, please contact your dealer for assistance.

Emergency Lowering Mechanism

Contact your dealer immediately if standard troubleshooting techniques do not correct the failure. Do not attempt to lift until all failure and safety issues have been resolved.

In case of lift failure, please follow the procedures below to safely lower the user.

The Emergency Lowering Device is located at the top of the actuator shaft. It is intended for use if the actuator or electronics fail to operate while the patient is suspended in midair. The device consists of a plastic collar ring that should be first pulled down and turned clockwise continually until the patient has been lowered.

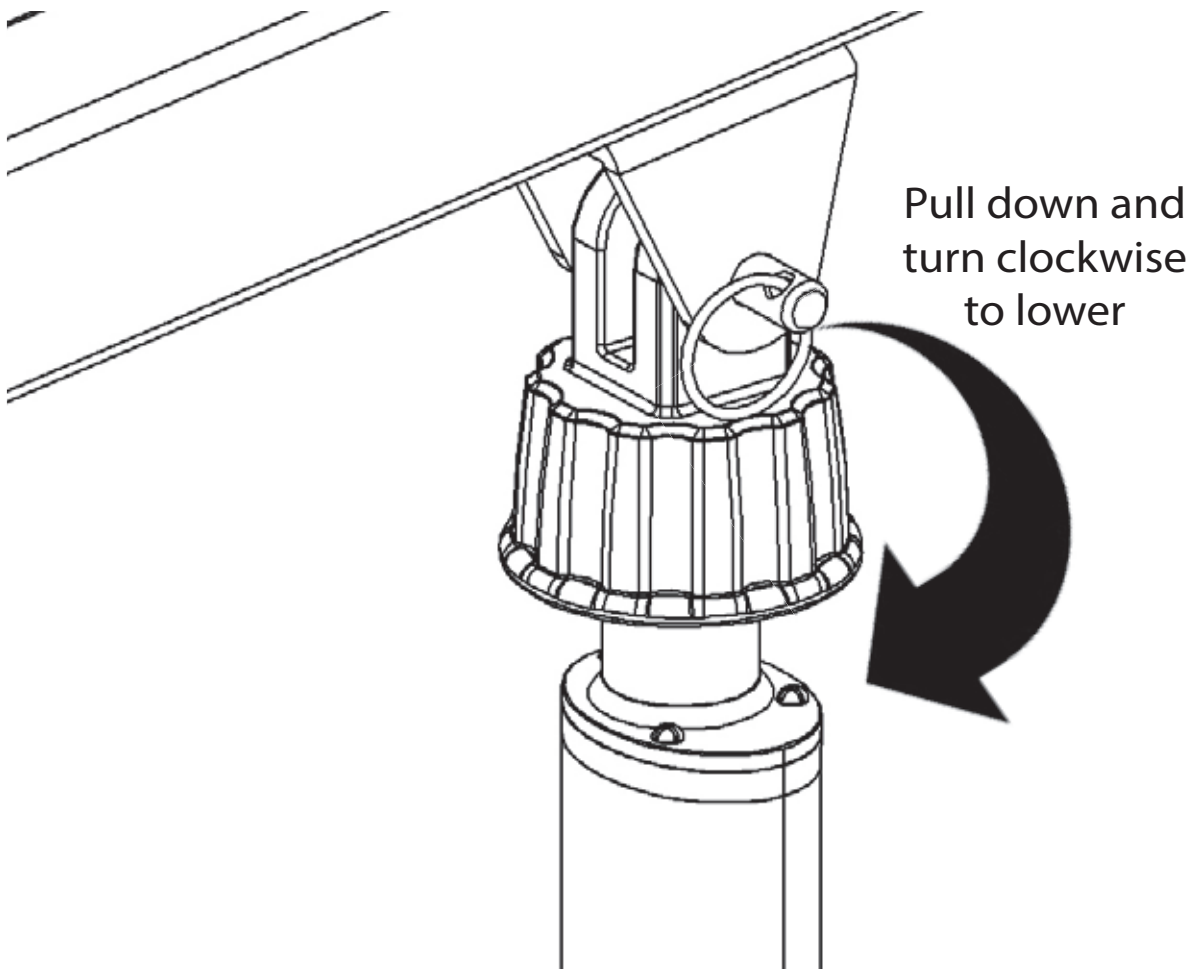

NOTE:
THE EMERGENCY LOWERING DEVICE IS INTENDED FOR USE DURING LIFT FAILURE. THIS DEVICE WILL ALLOW LOWERING OF PATIENTS ONLY. PLEASE CONTACT YOUR DEALER IMMEDIATELY IN CASE OF FAILURE.

Notes

Notes

The Protekt® 600 Stand Lift you purchased is guaranteed to be free from defects in material and workmanship under normal use and service. The warranty period for this product is 2 Years Electronics/3 Years Frame from the date of purchase by the original purchaser. This warranty shall be voided upon transfer of ownership of this product. Proactive Medical agrees to repair or replace this product, at our discretion and at no charge, within the warranty period provided and that Proactive Medical consents the unit is defective. The repaired or replacement unit shall be warranted for a period equal to the balance of the defective unit's warranty period.

This warranty shall not apply to any product which has been repaired or altered in any way so as, in our judgment, to affect its functionality and durability, nor to any product subject to abuse, misuse, negligence or accident, improper maintenance, improper installation, nor to any product used with other parts, components and/or accessories with quality and/or specifications not compatible with this product. This warranty does not cover products that have been impaired by occurrences considered Acts of God over which authorized dealer has no control. This warranty shall also be voided if any required periodic maintenance, if applicable, has not been properly performed on this product.

This warranty and the aforementioned remedies presented are exclusive and in lieu of all other express or implied warranties. No other representations or claims shall be binding or obligate authorized dealer in any way. Any warranty applicable to this product is limited to the aforementioned period indicated. In no event shall authorized dealer be liable for any special, incidental, or consequential damages; loss of revenue; or cost of replacement goods; resulting from the use or malfunction of this product to the associated equipment on which and with which it is used. This warranty gives specific legal rights and you may be entitled to other rights that vary from state to state.

U P O OCO

In the case where a customer wants to return an unwanted product or in the rare case where a product needs to be replaced for warranty reasons;

C to er et rn

1. Please contact Proactive customer service to arrange a return authorization number (RA#). This RA# must be written clearly on the box to insure proper timely processing of returns.
2. The customer will be responsible to arrange and pay for return shipping.
3. Upon successful return of the product, an inspection will be made to determine that the product is new and in working condition.
4. Upon successful determination that the product is new and in working condition a full credit will be issued for the sales price of the returned product.
5. A 25% restock fee will apply to all returns and will be deducted from the credit along with all applicable shipping charges.

Exceptions to the restock fee may be requested and will be considered on a case-by-case basis.

Proactive maintains the highest standards in quality control of its manufacturing process. In the unlikely occurrence of a warranty claim Proactive will do its best to resolve the problem as soon as possible.

1. Please contact Proactive customer service as soon as the problem is realized to arrange a return authorization number (RA#). This RA# must be written clearly on the box to insure proper timely processing of returns.
2. In order to ensure that the customer receives the replacement part or parts as soon as possible the customer will be required to place an order for the replacement part or parts needed. (this will be credited upon successful return of the item under warranty if there is a manufacturer's defect).
3. The customer will be responsible to arrange and pay for return shipping. (this will be credited upon successful return of the item under warranty if there is a manufacturer's defect).
4. Upon successful return of the product, a warranty inspection will be made to determine that the product is not working because of a manufacture defect.
5. Upon successful determination of a manufacturer's defect a credit will be issued for the replacement part or product order and the shipping costs incurred in its return.

At Proactive Medical Products discretion, we will either repair or replace any product that does not comply with this warranty. All product warranties are void if the product has been misused or abused, if there have been unauthorized repairs, or if the law tag has been removed or tampered with.

Shipping Error

In the unlikely chance that there has been a shipping error Proactive will do its best to immediately rectify the situation.

1. Please contact Proactive customer service as soon as the error is realized to arrange a return authorization number (RA#). This RA# must be written clearly on the box to insure proper timely processing of returns.
2. Proactive will email the customer a return shipping label to ship the product back to Proactive.
3. Proactive will ship out the proper product to the proper location either same day or as soon as possible. Correct shipping and tracking information will be transmitted to the customer as soon as it is known.



Proactive Medical Products
270 Washington Street
Mount Vernon, NY 10553
Tel: 855-237-7622

www.proactivemedical.com